

1. (L) HEEL GUARD [HG-3L]
3. (L) STEP PLATE [KTM-125SP-L]
5. (L) EXTENSION PLATE (BK) [KTM-D39017EP-L]
7. (L) BASE PLATE (BK) [KTM-D39017BP-L]
9. STAND BRACKET (BK)
10. SHIFT PEDAL [SPD-14]
11. SHIFT ROD 100 [SRD-100]
13. FOOT PEG [PEG]
14. FOOT PEG END CAP [ST-002]
15. PEDAL TIP (DELRIN) [ST-001D18]
17. ROD END COLLAR 3 (GD) [RDED-CLR3]
19. PEG COLLAR 12 [PEGCLR-12]
26. SOCKET HEAD M8x15mm [SBT-M815] x 4
27. BUTTON HEAD M6 x 10mm [BBT-M610] x 2
28. BUTTON HEAD M6 x 20mm [BBT-M620]
29. BUTTON HEAD M8 x 25mm [BBT-M825]
32. HEX HEAD M6x18mm [HBT-M618]
33. HEX HEAD M8x40mm [HBT-M840]
34. SET SCREW M3x14mm [SSCW-M314]
35. STUD M6 x 45mm [STUD-M6]
38. JAM NUT M6 [JNT-6] x 2
39. REVERSE JAM NUT M6 [JNT-6L]
42. SMALL WASHER M8 [PWS-8]
43. SPLIT WASHER M8 [SWS-8]
44. MALE REVERSE ROD END M6 [RDED-M6L]

**POSITIONS**

	Forward	Up
1	25mm Forward	12.5mm Up
2	25mm Forward	25mm Up
3	12.5mm Forward	12.5mm Up
4	12.5mm Forward	25mm Up
5	0mm	25mm Up
6	0mm	37.5mm Up
7	12.5mm Back	25mm Up
8	12.5mm Back	37.5mm Up

Note: all measurements are in relation to the stock foot peg position (0 mm).

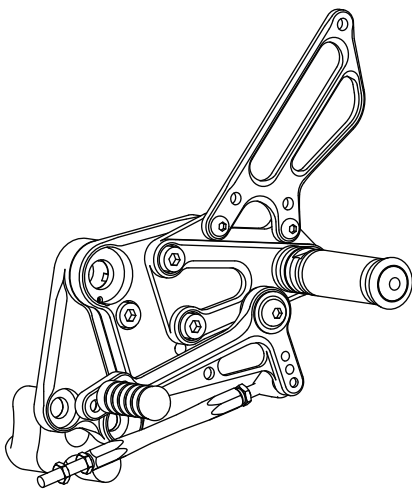

**\*STOCK KTM PARTS:**  
**49. WASHER**  
**50. ADJUSTER BOLT.**